



Flipchart Mobilechart Red

Product description 2x3 Article No: **TF17**

Characteristics: Designer line of Red Series flipcharts is characterised by modern shapes and vivid bold colours, with characteristic red elements which distinguish this line among the other products on the market. The 700 x 1000 mm board with permanent inclination angle of 15°; with the stylish shelf for the tools. The dry-wipe magnetic surface, varnish coated. Universal clamping grip for the blocks allows to exhibit A1 or EURO size sheets. The stable load-carrying structure of steel. The board height adjustable within 1600-1960 mm owing to the application of clamping eyes. The travelling base with lockable wheels.

Guarantee: 2 years for the product/10 years for the board surface.



Flipchart Mobilechart Red	
2x3 Article No	TF17
Surface	dry-wipe, varnished, scratchproof
Surface properties	magnetic
The board usable area dimensions	700 x 1000 mm
Maximum height	1600 – 1960 mm
Profile	aluminium
Adjustable grips	yes
Guarantee	2 years for the product, 10 years for the surface

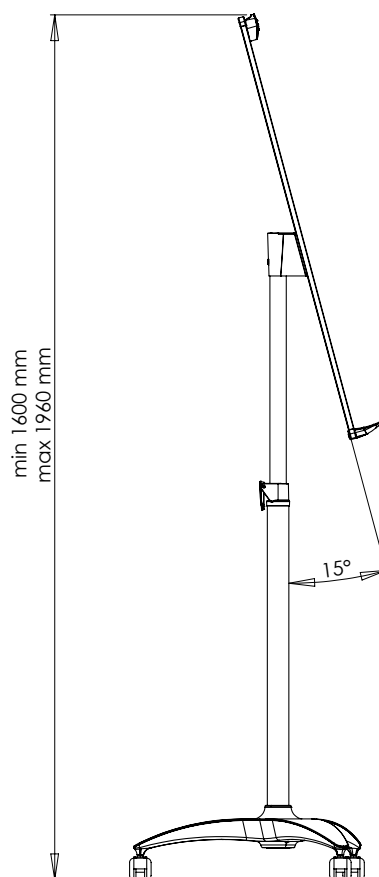
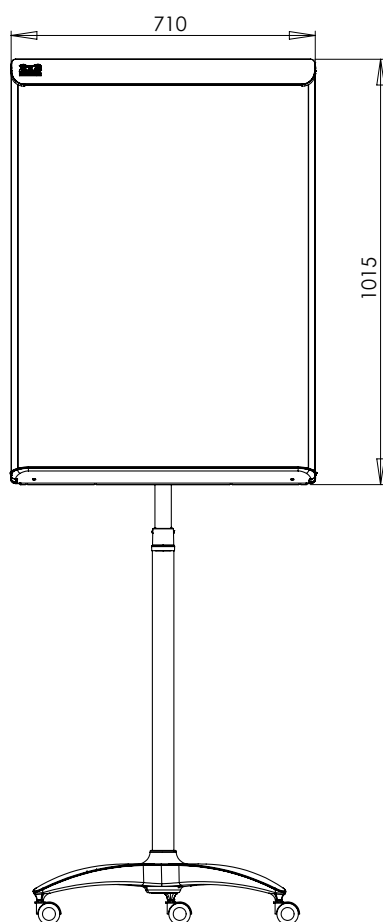

2x3 S.A.

73-231 Krzęcin, ul. Słoneczna 3, Polska

[i]: 801 23 00 23

[t]: +48 95 765 3848 [f]: +48 95 765 3850

[e]: info@2x3.pl [w]: www.2x3.eu